

23-14 920Kv Module

1 Features

Performance & Control

- Velocity control with tunable PIDs & 2nd order feed forward
- Field Estimated Control: Best-in-class efficiency
- Impossible to desync
- 3D reversible, no delay while crossing zero
- Industry-leading rise & response times
- Regenerative & active braking
- Active freewheeling
- Fast FET switching, use of gate drivers
- Voltage controller
- PWM controller
- Coast and brake modes
- No minimum speed
- Backdrivable

System Integration

- Motor with built-in ESC & position sensor
- Communication protocols: DShot (150-1200), 1-2ms PWM, Serial (UART) w/ access to control parameters, Oneshot (42,125), and Multi-shot

Safety & Reliability

- Over-current, over-voltage, over-speed & over-temperature protection
- Access to standard & custom telemetry
- Motor health monitoring
- Safe arming procedure

2 Applications

- Drone Propulsion
- Robotics



3 Description

The 23-14 920Kv Module is an ultra-compact, lightweight drone propulsion module that tightly integrates a high-performance 23-14 motor with a 30A continuous, 6S ESC and position sensor. It has an open and closed loop controller designed primarily to drive propeller loads. Its performance is comparable to or better than other 23-14 sized motors and can operate at any speed between -23,000 and 23,000 RPM thanks to its sensed control.

The motor can be driven with an integrated PID velocity controller with a second order polynomial feed forward, which is ideal for propeller applications. This sits on top of a voltage controller, which compensates for varying input voltages such as battery charge levels. Finally, the core is a raw PWM controller. Any of the above controllers can be used by the user.

4 Specifications

Table 1: Absolute Maximum Ratings

Description	Symbol	Min	Max	Unit	Notes
Supply Voltage	V_{CC}	-0.3	30	V	
Digital Logic Voltage	V_L	-0.3	7.3	V	3.3 V system, 5 V tolerant
MCU Temperature	T_{MCU}	-40	105	°C	Controller will self-limit performance when approaching max temperature
ESC Temperature	T_{ESC}	-40	85	°C	Maximin and minimax component ratings
Coil Temperature	T_c		120	°C	Controller will self-limit performance when approaching max temperature
Bearing Temperature	T_b	-20	80	°C	

Table 2: Recommended Operating Conditions

Description	Symbol	Min	Max	Unit	Notes
Battery Cells	S	2	6	S	Standard Li-on/po. Use w/ caution on 6S.
Power Supply Voltage	V_{CC}	5.4	25.2	V	Ensure motor regen does not exceed voltage limit. Use built in regen limiter or use an external load.
Ambient Temperature	T_a	-20	50	°C	Higher possible with reduced performance

Table 3: Properties

Description	Symbol	Value	Unit	Notes
Speed Constant	K_v	920	RPM/V	
Torque/EMF Constant	K_t	0.0104	N m A^{-1}	
Resistance	R	0.066	Ω	25°C
Effective Resistance	R	0.081	Ω	motor + controller, 25°C
Mass	m	62.9	g	Without wires/accessories
Continuous Torque	τ_c	130	N mm	In airflow, 25°C ambient
Continuous Current	I_S	12.5	A	Motor current, in airflow, 25°C ambient
Pulsed Current	I_{SP}	65	A	Motor current, 100ms, 25°C ambient
No Load Speed	ω_0	963	rad s^{-1}	@ $V_{CC} = 10 \text{ V}$
No Load Current	I_0	0.84	A	@ $V_{CC} = 10 \text{ V}$

5 Electrical Interface

5.1 Module Wiring



Figure 1: Connector Board

Table 4: Bottom Pin Out Descriptions

Pin No.	Name	Description
1	V-	Power ground, usually the negative battery terminal.
2	V+	Power high, usually the positive battery terminal.

Table 5: Top Pin Out Descriptions

Pin No.	Name	Description
3	RX/PWM	Controller RX / host TX and PWM input
4	TX/TELEM	Controller TX / host RX and telemetry output
5	GND	Negative terminal

5.1.1 Communication Wiring

Modules are shipped with a three-wire cable that includes a JR type servo connector with 15cm of wire. These connectors have 0.1 inch spacing and can be inserted into standard perfboard and breadboards with a 3x1 0.1 inch male-to-male header. The cable is typically soldered to the PCB as:

- Black is minus (ground).
- Red is motor controller TX (host RX) and telemetry output.
- White is motor controller RX (host TX) and pwm input.

5.1.2 Supply Wiring

Power is transmitted to the 23-14 920Kv Module via the two supplied 16 AWG (1.31 mm²), silicone encased, 15cm long wires.

- Black is minus (ground).
- Red is positive.

6 Mechanical Interface

6.1 Default Configuration

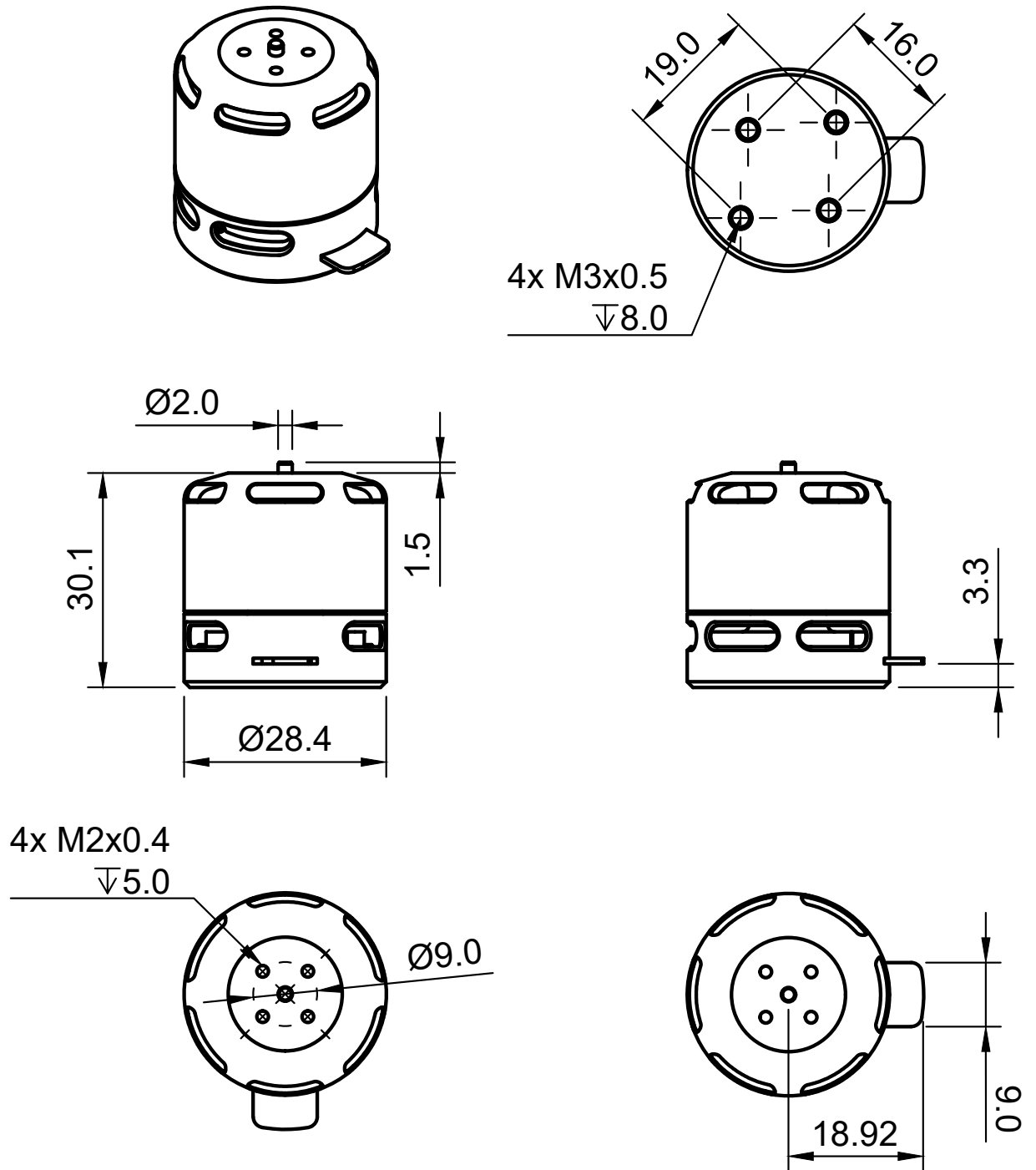

Included M5 propeller adapter not shown.

7 Safety Features

7.1 Over Current Protection

The ESC uses both a predictive and reactive method for over current protection. The motor controller will not apply a voltage which would put the controller or motor at risk of over current. If an overcurrent condition is detected, despite the predictive current protection, a reactive current protection will disable all MOSFETs. The reactive current protection can be configured for latching or non-latching behavior. Latching causes the controller to remain disabled until the user clears the error flag. Non-latching immediately recovers once the current lowers below the threshold. Non-latching is the default behavior.

7.2 Over Temperature Protection

The controller has an onboard temperature sensing circuit. If the temperature sensor detects a temperature that is approaching the controller's maximum temperature limit, the controller will begin to derate. While in derate, the module will spin at a lower speed and torque than expected. The controller will continue outputting as much power as possible without exceeding its thermal limit. If the controller's temperature drops, the controller will automatically exit derate mode and continue normal operation.

Though there is no temperature sensor in the motor's coils, the controller contains a predictive model which estimates the coil temperature. The same derating process as above is applied to the estimated coil temperatures, applying as much power as possible without causing damage. This protection ensures that large loads or stalled conditions do not overheat and damage the motor coils and magnets.

If an over temperature condition is detected, despite the predictive thermal protection, a reactive thermal protection will disable all MOSFETs. The reactive thermal protection can be configured for latching or non-latching behavior. Latching causes the controller to remain disabled until the user clears the error flag. Non-latching immediately recovers once the temperature lowers below the threshold. Non-latching is the default behavior.

7.3 Over Speed Protection

A soft limiter will reduce the voltage applied to the motor once ω_{max} is exceeded. The farther the speed is above ω_{max} the lower the output voltage of the controller. In extreme overspeed situations the motor acts as a brake, effectively shorting the three phases of the motor together. This will protect the motor from extremely large load changes, poor PID tuning values, and the unlikely chance of a runaway condition. This feature will fight an externally applied load that causes an over speed, but is not able to guarantee the prevention of an over speed condition in this situation.

7.4 Regeneration Voltage Protection

The 23-14 920Kv Module is a four quadrant motor-controller, which means it can both motor and generate in both directions. When the motor is generating, the voltage can spike if the connected electronics cannot absorb the energy that is being generated. Rechargeable batteries and capacitors can absorb this energy. Power supplies, diode-protected wiring, and some protected batteries do not absorb energy. This leads to a voltage spike that may destroy the motor and any attached equipment.

The controller can prevent these spikes from occurring by limiting the voltage applied to the motor. If an out of allowable range generation occurs, the motor will decrease its own generation, thereby protecting the circuitry. This protection does not prevent the damage from externally applied voltages.

7.5 Command Timeout Protection

A user settable timeout automatically disarms and puts the motor in to coast mode if it does not receive a valid message within a specified amount of time. The normal operation resumes upon receiving a new message.

7.6 Input Connection Protection

All exposed pins are protected with ESD diodes and a small amount of reverse polarity protection. Do not knowingly or intentionally apply reverse polarity or out of limit voltages to the exposed pins.

7.7 Watchdog Protection

In case of an unlikely error in the controller that causes it to freeze, the controller will automatically reboot. While this may allow for a recovery, all normal startup procedures are re-performed and any arming sequence or auxiliary commands must be redone.

8 Revision History

Table 6: Revision History

Version	Date	Changes
1.0	2023-07-18	Initial Version